

## Introduction

The following text describes the basic test procedures that can be used for most Harris Op Amps. Note that all measurement conversions have been taken into account in the equations stated.

### 1. Offset Voltage

The offset voltage ( $V_{IO}$ ) of the amplifier under test (AUT) is measured via Test Circuit 1 as follows:

1. Set  $V_+$  and  $V_-$  supplies to values specified in Table 1, Column (1) and  $V_{DC}$  to 0V.
2. Close  $S_1$  and  $S_2$ , open  $S_3$ .
3. Choose:  $R_F = 50K$  for non-precision amplifiers.  
 $R_F = 5M$  for precision amplifiers.
4. Measure voltage at E in volts (label as  $E_1$ ).  
 $V_{IO} = E_1$  (mV) for  $R_F = 50K$ , or  
 $V_{IO} = E_1 * 10$  ( $\mu V$ ) for  $R_F = 5M$

The gain of this circuit with  $R_F = 50K$  ( $R_F = 5M$ ) requires the output to be driven to 1000 (100,000) times the offset voltage necessary to maintain the output of the AUT at 0V. Note that the AUT output is always identical to  $V_{DC}$ . Overall circuit stability is maintained by the adjustable feed-back capacitor  $C_A$ .

### 2. Input Bias Current

The bias current flowing in or out of the positive terminal of the AUT ( $I_{B+}$ ) is obtained using Test Circuit 1 by:

1. Measuring  $E_1$  as in procedure 1 (use  $R_S = 100K$  for JFET input devices).
2. Maintain  $V_{DC}$  at 0V.
3. Close  $S_2$ , open  $S_1$  and  $S_3$ .
4. Measuring voltage at E in volts (label as  $E_2$ ).  
 $I_{B+} = (E_1 - E_2) \times 100$  (nA) for  $R_F = 50K$ ,  $R_S = 10K$ , or  
 $I_{B+} = (E_1 - E_2) \times 10$  (nA) for  $R_F = 50K$ ,  $R_S = 100K$

The bias current flowing in or out of the negative terminal ( $I_{B-}$ ) is found by:

1. Following steps 1 and 2 for  $I_{B+}$ .
2. Close  $S_1$ , open  $S_2$  and  $S_3$ .
3. Measuring voltage at E in volts (label as  $E_3$ ).  
 $I_{B-} = (E_1 - E_3) \times 100$  (nA) for  $R_F = 50K$ ,  $R_S = 10K$ , or  
 $I_{B-} = (E_1 - E_3) \times 10$  (nA) for  $R_F = 50K$ ,  $R_S = 100K$

### 3. Input Offset Current

Using Test Circuit 1, the input offset current ( $I_{IO}$ ) of the AUT is determined by:

1. Measuring  $E_1$  as in procedure 1.
2. Maintaining  $V_{DC}$  at 0V.

3. Open  $S_1$ ,  $S_2$  and  $S_3$ .
4. Measuring voltage at E in volts (label as  $E_4$ ).  
 $I_{IO} = (E_1 - E_4) \times 100$  (nA) for  $R_F = 50K$ ,  $R_S = 10K$ , or  
 $I_{IO} = (E_1 - E_4) \times 10$  (nA) for  $R_F = 50K$ ,  $R_S = 100K$

### 4. Power Supply Rejection Ratio

Both positive and negative PSRRs are measured via Test Circuit 1. For PSRR+:

1. Close  $S_1$  and  $S_2$ , open  $S_3$ .
2. Choose:  $R_F = 50K$
3. Set  $V_{DC} = 0$ ,  $V_+ = 10V$ , and  $V_- = -15V$ .
4. Measure voltage at E in volts (label as  $E_5$ ).
5. Change  $V_+$  to +20V.
6. Measure voltage at E in volts (label as  $E_6$ ).

$$PSRR + = 20 \log_{10} \left| \frac{10^4}{E_5 - E_6} \right| \text{ (dB) for } R_F = 50K$$

Similarly for PSRR-:

1. Follow steps 1 and 2 for PSRR+ above.
2. Set  $V_{DC} = 0V$ ,  $V_+ = +15V$ ,  $V_- = -10$ .
3. Measure voltage at E in volts (label as  $E_7$ ).
4. Change  $V_-$  to -20V.
5. Measure voltage at E in volts (label as  $E_8$ ).

$$PSRR - = 20 \log_{10} \left| \frac{10^4}{E_7 - E_8} \right| \text{ (dB) for } R_F = 50K$$

### 5. Common Mode Rejection Ratio

The CMRR is determined by adjusting Test Circuit 1 as follows:

1. Close  $S_1$  and  $S_2$ , open  $S_3$ .
1. Choose:  $R_F = 50K$
2. Set  $V_+ = +5V$ ,  $V_- = -25V$ , and  $V_{DC} = -10V$ .
3. Measure voltage at E in volts (label as  $E_9$ ).
4. Set  $V_+ = 25V$ ,  $V_- = -5V$ , and  $V_{DC} = 10V$ .
5. Measure voltage at E in volts (label as  $E_{10}$ ).

$$CMRR = 20 \log_{10} \left| \frac{2 \times 10^4}{E_9 - E_{10}} \right| \text{ (dB) for } R_F = 50K$$

### 6. Output Voltage Swing

Test Circuit 2 is adjusted to measure  $V_{OUT+}$  and  $V_{OUT-}$  the procedure is:

1. Select appropriate  $V_+$  and  $V_-$  supply values from Table 1, Column 1.

2. Select specified  $R_L$  from Table 1, Column 2.
3. Set  $V_{IN} = 0.5V$ .
4. Measure voltage at E in volts.  $V_{OUT+} = E$  (V)

Similarly  $V_{OUT-}$  is found by:

1. Selecting specified  $R_L$  from Table 1, Column 1.
2. Setting  $V_{IN} = -0.5V$ .
3. Measuring voltage at E in volts.  
 $V_{OUT-} = E$  (V)

### 7. Output Current

The output current corresponding to the output voltage of procedure 6 is found by:

1. Measuring  $V_{OUT-}$  and  $V_{OUT+}$  as in procedure 6.

$$I_{OUT+} = \frac{V_{OUT+}}{R_L} \text{ where } R_L \text{ is from Table 1, Column 2.}$$

$$I_{OUT-} = \frac{V_{OUT-}}{R_L} \text{ where } R_L \text{ is from Table 1, Column 2.}$$

### 8. Open Loop Gain

Both positive ( $A_{VOL+}$ ) and negative ( $A_{VOL-}$ ) open loop gain measurements are determined by adjusting Test Circuit 1.

For  $A_{VOL+}$ :

1. Close  $S_1$ ,  $S_2$  and  $S_3$ .
2. Select specified  $R_L$  from Table 1, Column 3.
3. Set  $R_F = 50K$ .
4. Set  $V_{DC} = 0V$ ,  $V_+ = +15V$ , and  $V_- = -15V$ .
5. Measure voltage at E in volts (label as  $E_{13}$ ).
6. Set  $V_{DC} = 10V$ .
7. Measure voltage at E in volts (label as  $E_{14}$ ).

$$A_{VOL+} = \frac{10}{E_{14} - E_{13}} \text{ (V/mV) for } R_F = 50K$$

For  $A_{VOL-}$ :

1. Follow steps 1, 2, 3, 4, and 5 above.
2. Set  $V_{DC} = -10V$ .
3. Measure voltage at E in volts (label as  $E_{15}$ ).

$$A_{VOL-} = \frac{10}{E_{13} - E_{15}} \text{ (V/mV) for } R_F = 50K$$

### 9. Slew Rate

Test Circuit 3 is used for measurement of positive and negative slew rate. For  $SR+$ :

1. Select specified  $R_L$ ,  $A_{CL}$ , and  $C_L$  from Table 1, Columns 4, 5 and 6.
2. Apply a positive step voltage to  $V_{AC}$  (refer to data book for test waveform).
3. Observe  $\Delta V$  and  $\Delta t$  at E. A standard approach is to use the 10% and 90% points or else the 25% and 75% points on the waveform.

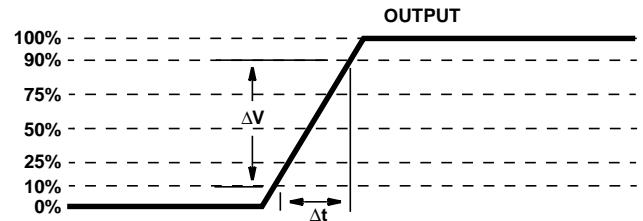

$$SR = \frac{\Delta V}{\Delta t}$$

For  $SR-$  repeat above procedure with negative input pulse.

$$SR- = \frac{\Delta V}{\Delta t}$$

### 10. Full Power Bandwidth

Full power bandwidth is calculated by:

1. Measuring slew rate as above in procedure 9.
2. Measuring  $V_{OUT+}$  as in procedure 6. (Typically  $V_{OUT+}$  is assumed to be the guaranteed minimum  $V_{OUT-}$ , usually 10V.)

$$FPBW = \frac{SR+}{2\pi V_{OUT(PEAK)}}$$

### 11. Rise Time, Fall Time and Overshoot

The small signal step response of the AUT is determined via Test Circuit 3. The procedure requires:

1. Selecting the appropriate  $R_L$ ,  $A_{CL}$ , and  $C_L$  from Table 1, Columns 4, 5 and 6.
2. Applying a positive input step voltage for rise time  $t_R$  and positive overshoot  $OS+$ .  
Applying a negative input step voltage for fall time  $t_F$  and negative overshoot  $OS-$ .  
(Refer to data book for input waveforms.)
3. Observe output of AUT noting the key points as shown.

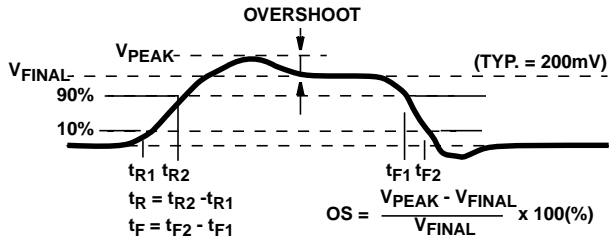

## 12. Settling Time

Test Circuit 6 is appropriate for settling time ( $t_S$ ) measurement, the procedure is:

1. Select  $R_1$  and  $R_2$  such that AUT is at the  $A_{CL}$  stated in Table 1, Column 5.
2. Select  $R_3$  and  $R_4$  so that  $R_3 \geq 2R_1$  and  $R_4 \geq 2R_2$  with the condition that the ratio

$$\frac{R_3}{R_4} = \frac{R_1}{R_2} \text{ be maintained.}$$

3. Apply step voltage as specified in data book.
4. Measure the time from  $t_1$  (time input step applied) to  $t_2$  (the time  $E_S$  settles to within a specified percentage of  $V_{OUT}$  - see data book).  $t_S = t_2 - t_1$

NOTE: Clipping diodes of Test Circuit 6 prevent overdrive of oscilloscope. (Recommend fast Schottky diodes.)

## 13. Gain Bandwidth Product

Test Circuit 4 is used for measuring GBP. The procedure is:

1. Sweep  $V_{IN}$  thru the required frequency range.
2. With a network analyzer view gain (dB) versus frequency as below.

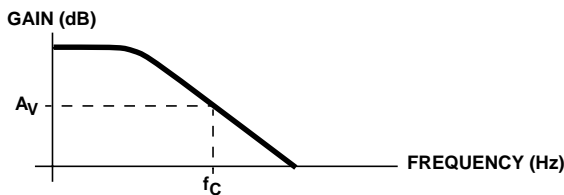

3. At the voltage gain of interest ( $A_V$ ) determine the corresponding frequency  $f_C$ . Note that chosen  $A_V$  must be greater than or equal to that stated in column 5 of Table 1.  $GBP = A_V \times f_C$  (Hz) where  $A_V$  is in V/V.

## 14. Phase Margin (Network Analyzer Method)

Test Circuit 4 is used to obtain phase margin measurement. The procedure is:

1. Sweep  $V_{IN}$  thru the required frequency range.
2. Display gain in dB and phase in degrees versus frequency on analyzer as shown.

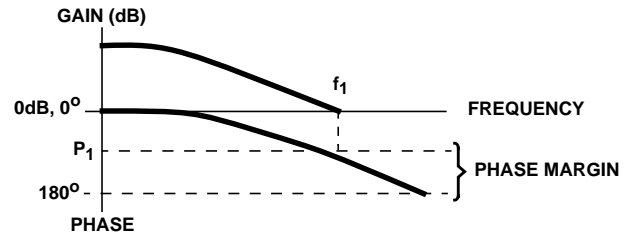

3. At a gain of 0dB (if  $A_{CL} = 1$  in Table 1, column 5), record frequency  $f_1$  and corresponding phase  $P_1$ . Phase margin = 180 degrees -  $P_1$  degrees.

## 15. Input Noise Voltage

Test Circuit 5 is designed for measuring input noise voltage. Use of the Quantec Noise Analyzer is recommended to obtain measurements at 1Hz bandwidth around a specific center frequency. The procedure is:

1. Set  $R_G = 0$
2. Set circuit card to gain of 10.
3. Select measurement frequency of interest.
4. Record noise voltage (label as  $E_{n1}$ ). Units are  $nV/\sqrt{Hz}$ .

## 16. Input Noise Current

Using Test Circuit 5, the input noise current is obtained by:

1. Measure  $E_{n1}$  as above for the desired frequency of interest.
2. Adjust  $R_G$  so that  $V_O > 2E_{n1}$  (label  $V_O$  as  $E_{n2}$ ).

$$I_n = \sqrt{\frac{(E_{n2})^2 - (E_{n1})^2 - 4kTR_G}{R_G^2}}$$

Where  $K = 1.38 \times 10^{-23}$  (Boltzmann's Constant)  
 $T = 300^\circ\text{C} (27^\circ\text{C})$

## 17. Channel Separation (Crosstalk)

Test Circuit 7 is used to measure channel separation (CS). The procedure is as follows:

1. Apply  $V_{IN}$  at the frequency of interest to input of channel 1.
2. Select  $R_L$  from Table 1, column 4.
3. Measure  $V_{O1}$ .
4. Measure  $V_{O2}$  of channel 2.

$$CS = 20 \log_{10} \left| \frac{V_{O2}}{100V_{O1}} \right| \text{ dB}$$

## Application Note 551

TABLE 1.

PART NUMBER	(1) SUPPLY VOLTAGE (V <sub>S</sub> )	PARAMETERS TO MEASURE				
		(2) V <sub>OUT</sub> R <sub>L</sub> (kΩ)	(3) A <sub>VOL</sub> R <sub>L</sub> (kΩ)	SLEW RATE, OS, t <sub>R</sub> , t <sub>F</sub>		
				(4) R <sub>L</sub> (kΩ)	(5) A <sub>CL</sub>	(6) C <sub>L</sub> (pF)
HA-2400/04/05	±15	2	2	2	1	50
HA-2500/02/05	±15	2	2	2	1	50
HA-2510/12/15	±15	2	2	2	1	50
HA-2520/02/05	±15	2	2	2	3	50
HA-2539	±15	1	1	1	10	10
HA-2540	±15	1	1	1	10	10
HA-2541	±15	2	2	2	1	10
HA-2542	±15	1	1	1	2	10
HA-2600/02/05	±15	2	2	2	1	100
HA-2620/02/05	±15	2	2	2	5	50
HA-2640/05	±40	5	5	5	1	50
HA-4741	±15	10	2	2	1	50
HA-5101	±15	2	2	2	1	50
HA-5102/04	±15	2	2	2	1	50
HA-5111	±15	2	2	2	10	50
HA-5112/14	±15	2	2	2	10	50
HA-5127	±15	0.6	2	2	1	50
HA-5130/05	±15	0.6	2	2	1	100
HA-5134	±15	2	2	2	1	50
HA-5137	±15	0.6	2	2	5	50
HA-5141/12/14	+5/0	50	50	50	1	50
HA-5147	±15	0.6	2	2	10	50
HA-5151/12/14	±15	10	10	10	1	50
HA-5160/62	±15	2	2	2	10	50
HA-5170	±15	2	2	2	1	50
HA-5180	±15	2	2	2	1	50
HA-5190/95	±15	0.2	0.2	2	5	10

Test Circuits

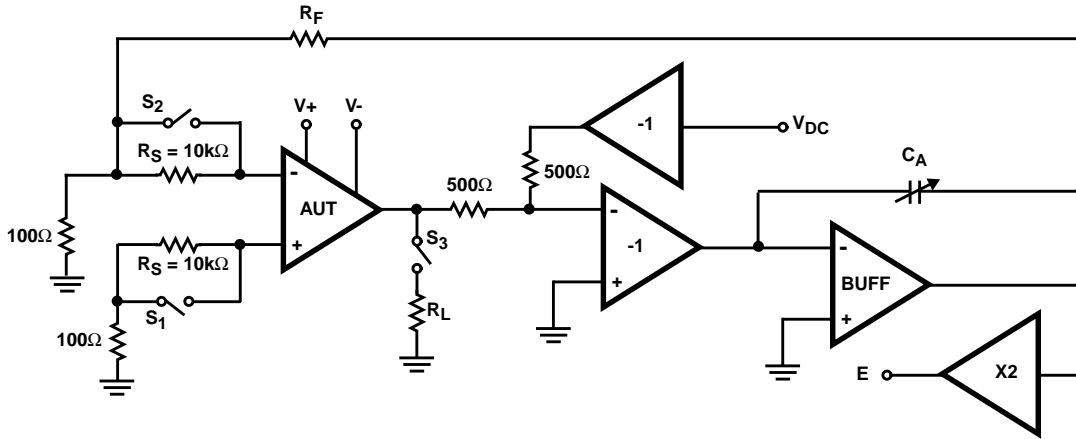

TEST CIRCUIT 1

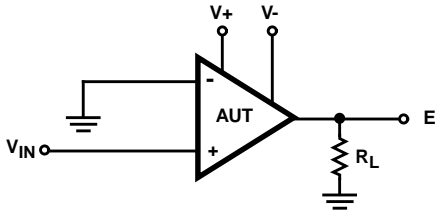

TEST CIRCUIT 2

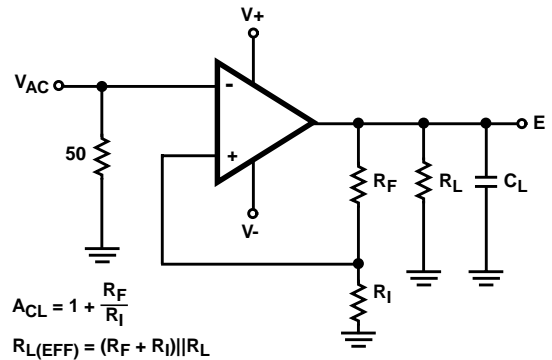

TEST CIRCUIT 3

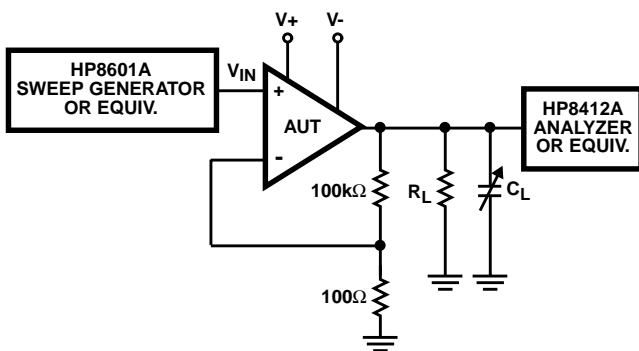

TEST CIRCUIT 4

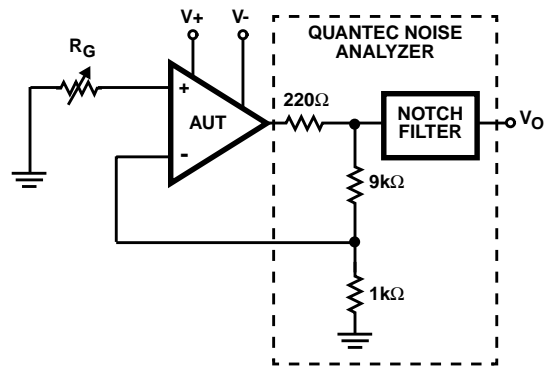

TEST CIRCUIT 5

Test Circuits (Continued)

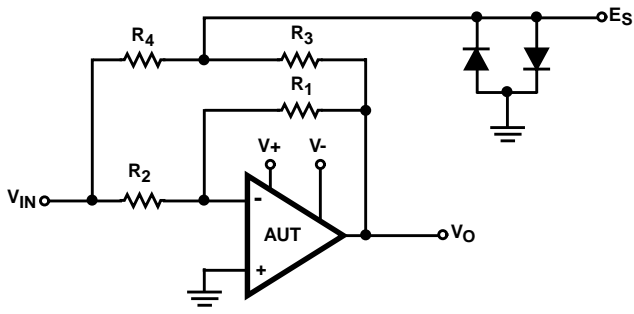

TEST CIRCUIT 6

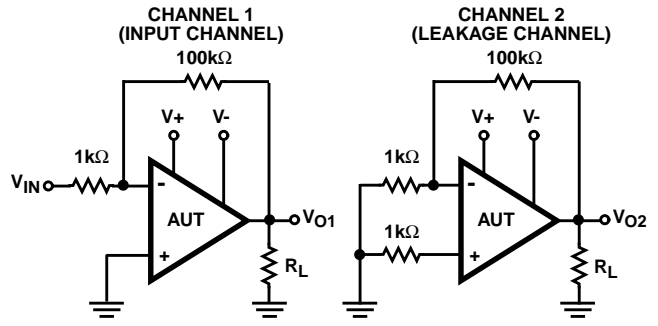

TEST CIRCUIT 7